

Straightaway 720 Bottom Rolling Door Gear

FOR DOORS ON SINGLE AND DOUBLE PARALLEL TRACKS

APPLICATION

Bottom rolling straight sliding doors for car showrooms and large glass window installations where mortice rollers are needed. Single or multiple runs of tracks.

RANGE

Maximum door weight 400kg (880 lb)
Maximum door height 3.5m (11ft)

Consider wind pressure in exposed positions, if in doubt consult gear makers. Door thickness 44mm minimum.

DOOR CONSTRUCTION

Timber doors only with deep bottom rails to accommodate mortice bottom rollers. Mortices should fit closely around roller housing. Door areas and glass sizes should be considered in relation to wind pressure and exposure.

FIXING

Track brackets side or soffit fixed. Floor track is set flush. Lateral adjustment with double side fixed brackets.

BOTTOM ROLLERS

72-402 Ball bearing, machined steel wheels, die cast casing. Packed in pairs. Self-colour finish.

BOTTOM TRACK

72-3 Brass (Set flush only). Lengths 1.8m to 3.0m.

TOP GUIDES

8-362 Rattleproof, twin neoprene wheels.

TOP TRACK

8-25 Safety pattern, galvanised steel to BS EN 10142. Lengths 1.8m to 3.0m.

TOP TRACK BRACKETS

Malleable iron and steel. See drawing and full range details on pages 3-4.

FURNITURE

A range of door furniture and locking arrangements is available.

DOOR STOPS

Must be positioned so that fingers cannot be trapped between doors on double runs.

FINISHES

Top track galvanised; bottom rollers and brackets plated. Bottom track brass.

DRAUGHT EXCLUDER

97-774 Brush Welt with aluminium retaining strip available in 2.4m lengths.

EXAMPLE

Quantities for a two leaf framed door sliding within the opening. Opening 6m wide x 2.4m high. 2 doors on double track.

A TYPICAL BILL OF QUANTITIES

ITEM				
A	8-25	Track 4 x 3.0m	12	LIN.M
B	8-150	Brackets, open, soffit fixing	16	NO.
C	8-051	Closed end piece	4	NO.
D	8-152	Brackets, lock joint, soffit fixing	2	NO.
E		Bolts for brackets (by others)	36	NO.
F	8-362	Twin wheel top guides & screws	4	NO.
G	72-402	Bottom rollers and screws (pair)	2	NO.
H	72-3	Brass bottom track 4 x 3.0m	12	LIN.M
J	95-617	Flush handles and screws	4	NO.
K		Door stops		
L		Locking arrangements		
M		Weatherstrips by others		

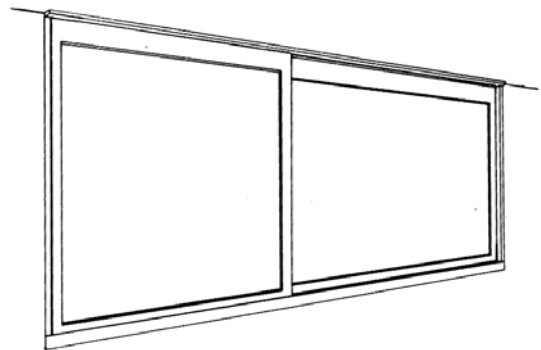

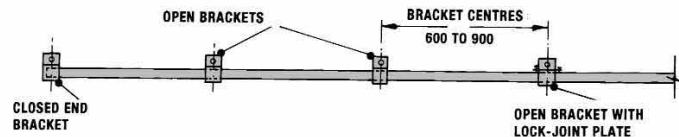

STANDARD TRACK LENGTHS			
1.8	2.1	2.4	3.0 METRES

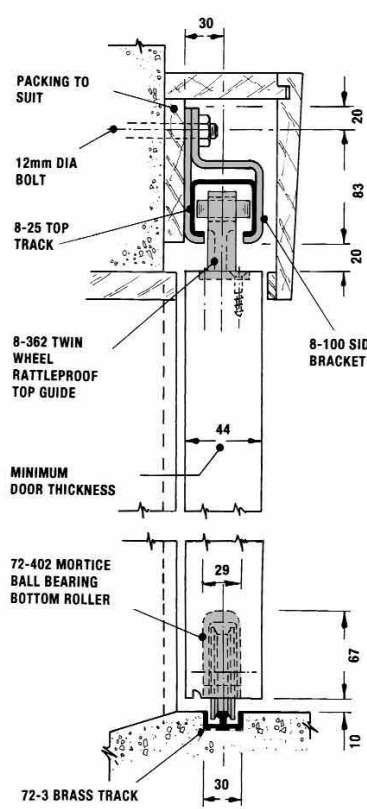

SECTION THROUGH SINGLE DOOR-SIDE FIXED



8-25 SAFETY TOP GUIDE TRACK SECTION

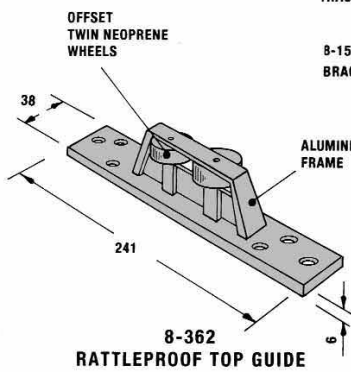

8-362 RATTLEPROOF TOP GUIDE

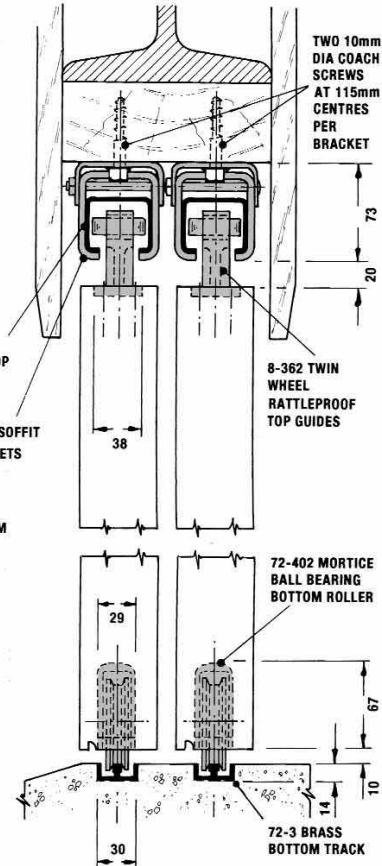

SECTION THROUGH DOUBLE DOORS - SOFFIT FIXED

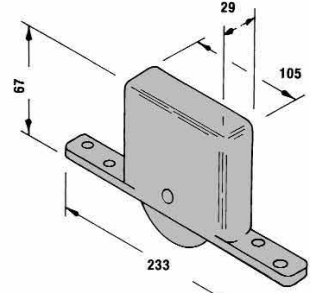

72-402 BOTTOM ROLLER

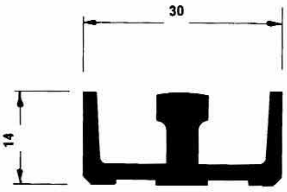

72-3 BRASS BOTTOM TRACK SECTION

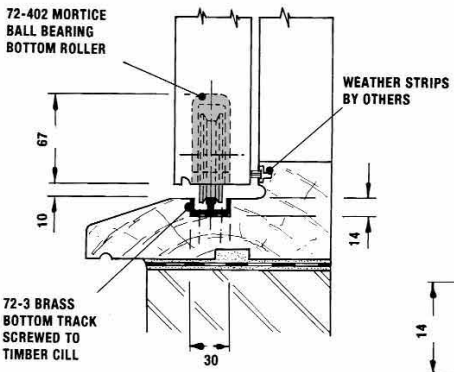

ALTERNATIVE SECTION TIMBER CILL

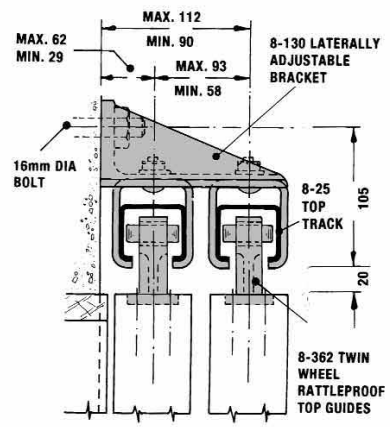

ALTERNATIVE HEAD SECTION DOUBLE TRACK