

# Solo Vitesse Sliding Door Gear

**FOR USE WHERE QUIET OPERATION AND MINIMUM EFFORT ARE REQUIRED**

## APPLICATION

Internal straight sliding door gear for domestic and similar use.

## RANGE

- Maximum door weight 50kg (110lb).
- Maximum door height 2.1 m (7ft).
- Maximum door width 900mm (3ft).

## DOOR CONSTRUCTION

Door thickness 30-44mm.

## FIXING

Top track side fixed. For soffit fixing use timber bearer secured to soffit first. Single screw fixed guides on floor keep threshold clear. Not suitable for self-closing doors. Hanger carriage has vertical and lateral adjustment. Use two sets for bi-parting doors.

## HANGER CARRIAGE

All steel, one carriage containing 2 differential nylon wheels with integral high tensile phosphor bronze pins.

## TRACK

Galvanised steel drilled for side fixing. Length 1524mm.

## DOOR PLATES

Steel, zinc plated with vertical and lateral adjustment.

## DOOR STOP

97-726 Nylon with rubber buffer.

## DOOR CHANNEL

Galvanised steel drilled and c/sk for wood.

## FLOOR GUIDE

Nylon, single screw fixing.

## FURNITURE

Full range of door furniture shown on page 3.

## SOLO VITESSE SLIDING DOOR GEAR

### STANDARD TRACKSETS

"Solo Vitesse" Sliding door gear is available in one standard pack only for doors up to 900mm wide. Contents per set: 1 length top track, hanger assembly, door plates, door channel for housing into underside of door, nylon door guide, alternative 97-780 bottom guide, door stop, installation details & all screws.

### PELMETS

Galvanised steel  
97-707-3 Length 1.8m.  
97-707-5 Length 2.4m.

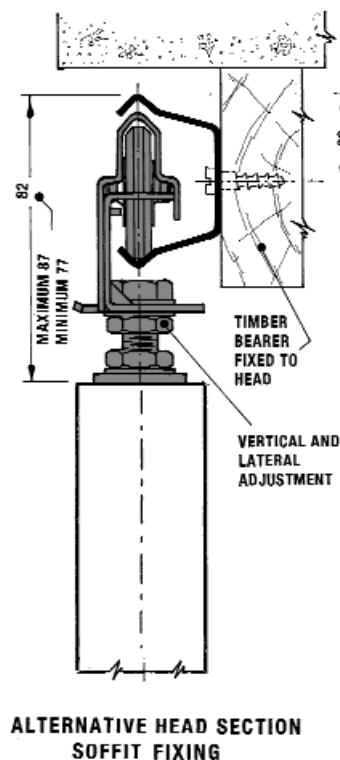
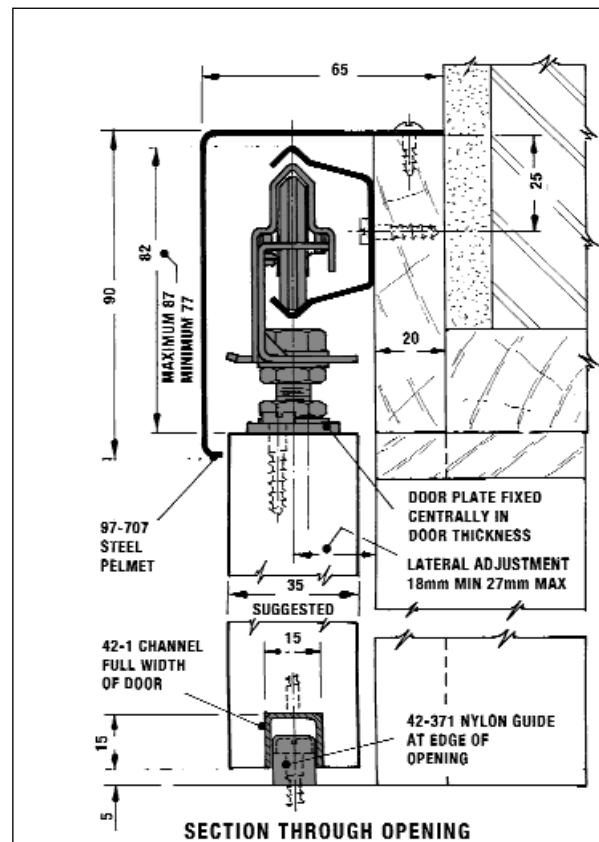

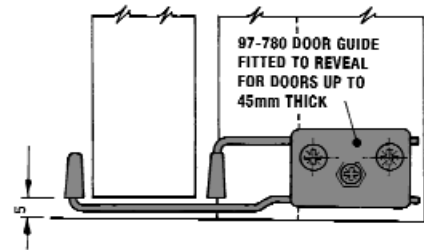
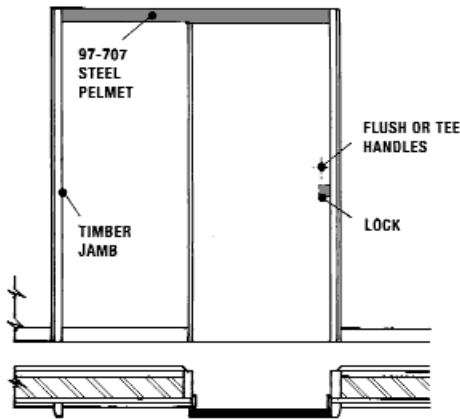
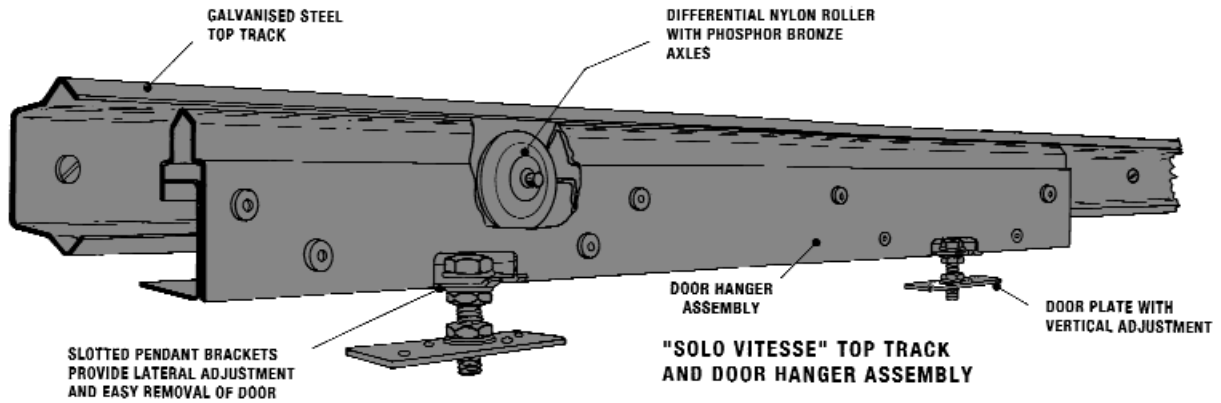

**BI - PARTING DOORS**  
 BUTT TRACKS AT CENTRE OF OPENING AND FIT INTERLOCKING FILLETS AT TRAILING EDGES TO PREVENT DOORS PASSING BEYOND CENTRE OF OPENING-SEE PLAN BELOW

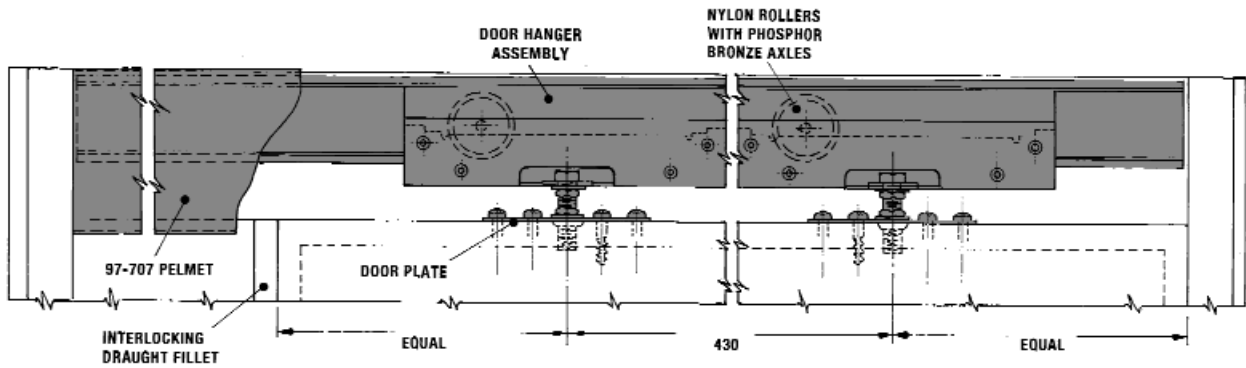

**PLAN AND ELEVATION- DOOR ON FACE OF WALL**

